

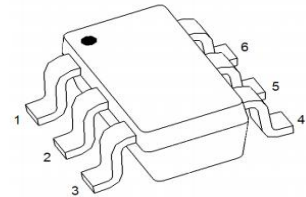

### DMMT5401 PNP Transistors

■ Features

- Epitaxial Planar Die Construction
- Complementary NPN Type Available (DMMT5551)
- Ideal for Medium Power Amplification and Switching
- Intrinsically Matched PNP Pair (Note 1)
- 2% Matched Tolerance,  $h_{FE}$ ,  $V_{CE(SAT)}$ ,  $V_{BE(SAT)}$
- 1% Matched Tolerance, Available (Note 2)
- Also Available in Lead Free Version
  
- Marking : K4S

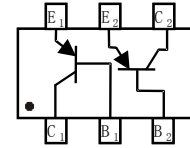

SOT23-6L

■ Absolute Maximum Ratings  $T_a = 25^{\circ}C$

Parameter	Symbol	Rating	Unit
Collector - Base Voltage	$V_{CB0}$	-160	V
Collector - Emitter Voltage	$V_{CE0}$	-150	
Emitter - Base Voltage	$V_{EB0}$	-5	
Collector Current - Continuous	$I_C$	-200	mA
Collector Power Dissipation	$P_D$	300	mW
Thermal Resistance, Junction to Ambient (Note 3)	$R_{\theta JA}$	417	K/W
Junction Temperature	$T_J$	150	$^{\circ}C$
Storage Temperature range	$T_{stg}$	-55 to +150	

Notes:

1. Built with adjacent die from a single wafer.
2. Contact the Diodes, Inc. Sales department.
3. Device mounted on FR-4 PCB, 1 inch x 0.85 inch x 0.062 inch; pad layout as shown on Diodes Inc. suggested pad layout document AP02001, which can be found on our website at



■ Electrical Characteristics Ta = 25°C

Parameter	Symbol	Test Conditions	Min	Typ	Max	Unit
Collector- base breakdown voltage	V <sub>CB0</sub>	I <sub>C</sub> = -100 μA, I <sub>E</sub> =0	-160			V
Collector- emitter breakdown voltage	V <sub>CEO</sub>	I <sub>C</sub> = -1 mA, I <sub>B</sub> =0	-150			
Emitter - base breakdown voltage	V <sub>EB0</sub>	I <sub>E</sub> = -100 μA, I <sub>C</sub> =0	-5			
Collector-base cut-off current	I <sub>CB0</sub>	V <sub>CB</sub> = -120V, I <sub>E</sub> = 0			-50	nA
		V <sub>CB</sub> = -120V, I <sub>E</sub> = 0, T <sub>A</sub> = 100°C				μA
Emitter cut-off current	I <sub>EB0</sub>	V <sub>EB</sub> = -3.0V, I <sub>C</sub> = 0			-50	nA
Collector-emitter saturation voltage	V <sub>CE(sat)</sub>	I <sub>C</sub> = -10mA, I <sub>B</sub> = -1.0mA			-0.2	V
		I <sub>C</sub> = -50mA, I <sub>B</sub> = -5.0mA			-0.5	
Base - emitter saturation voltage	V <sub>BE(sat)</sub>	I <sub>C</sub> = -10mA, I <sub>B</sub> = -1.0mA			-1	
		I <sub>C</sub> = -50mA, I <sub>B</sub> = -5.0mA				
DC current gain	h <sub>FE</sub>	I <sub>C</sub> = -1.0mA, V <sub>CE</sub> = -5.0V	50			
		I <sub>C</sub> = -10mA, V <sub>CE</sub> = -5.0V	60		240	
		I <sub>C</sub> = -50mA, V <sub>CE</sub> = -5.0V	50			
Small Signal Current Gain		V <sub>CE</sub> = -10V, I <sub>C</sub> = -1.0mA, f = 1.0kHz	40			
Collector output capacitance	C <sub>ob0</sub>	V <sub>CB</sub> = -10V, f = 1.0MHz, I <sub>E</sub> = 0			6	pF
Transition frequency	f <sub>T</sub>	V <sub>CE</sub> = -10V, I <sub>C</sub> = -10mA, f=100MHz	100		300	MHz
Noise Figure	N <sub>F</sub>	V <sub>CE</sub> = -5.0V, I <sub>C</sub> = -200uA R <sub>S</sub> = 10Ω, f=1.0kHz			8	dB



### Typical Characteristics

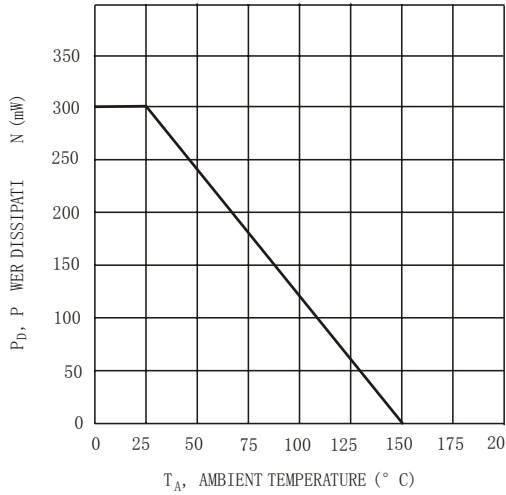

Fig. 1, Max Power Dissipation vs Ambient Temperature

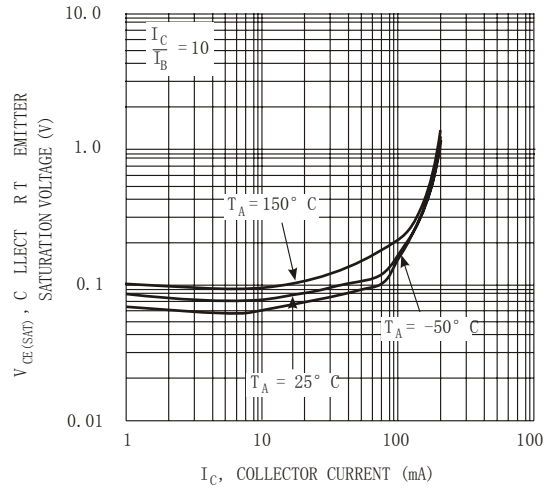

Fig. 2, Collector Emitter Saturation Voltage vs. Collector Current

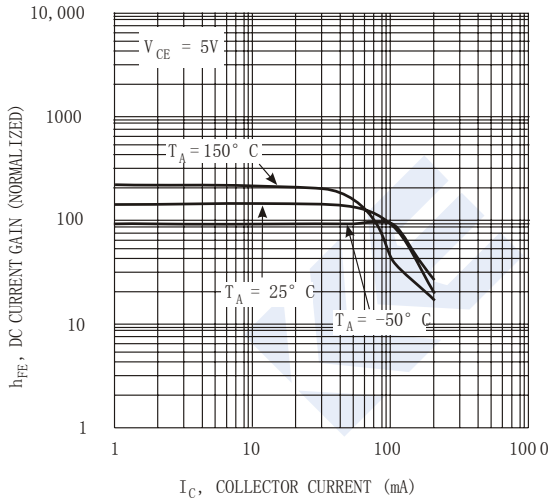

Fig. 3, DC Current Gain vs Collector Current

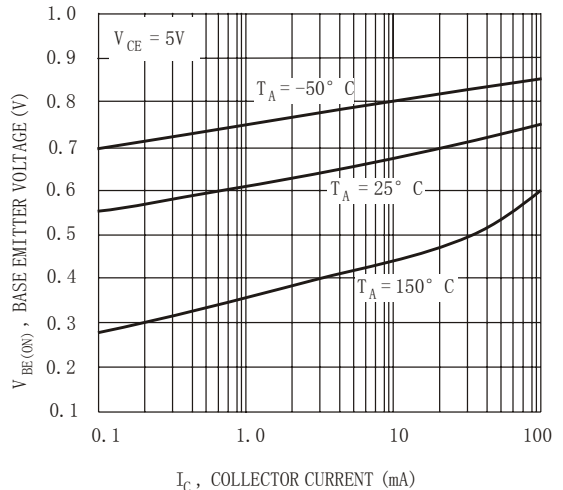

Fig. 4, Base Emitter Voltage vs. Collector Current

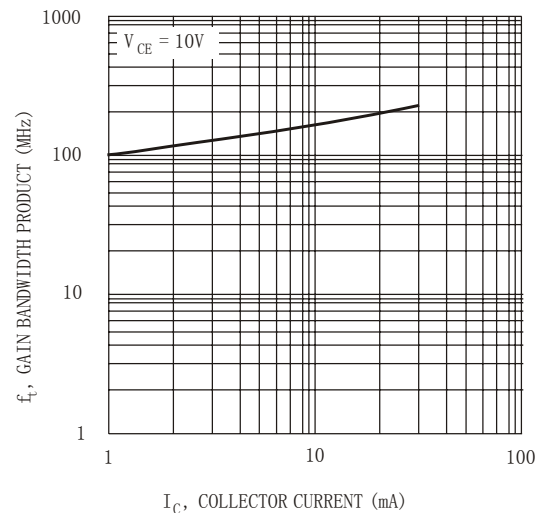
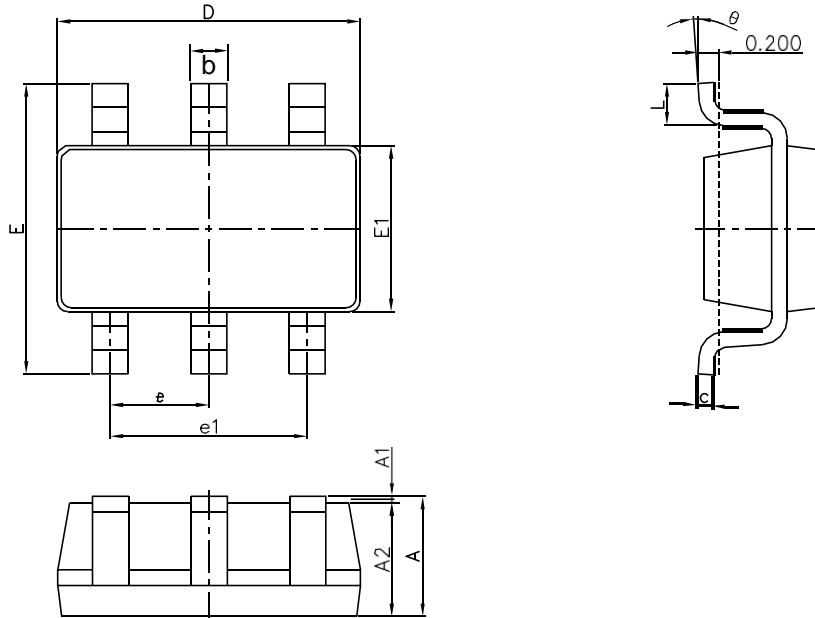

Fig. 5, Gain Bandwidth Product vs Collector Current



## SOT-23-6L Package Outline Dimensions



Symbol	Dimensions In Millimeters		Dimensions In Inches	
	Min.	Max.	Min.	Max.
A	1.050	1.250	0.041	0.049
A1	0.000	0.100	0.000	0.004
A2	1.050	1.150	0.041	0.045
b	0.300	0.500	0.012	0.020
c	0.100	0.200	0.004	0.008
D	2.820	3.020	0.111	0.119
E1	1.500	1.700	0.059	0.067
E	2.650	2.950	0.104	0.116
e	0.950(BSC)		0.037(BSC)	
e1	1.800	2.000	0.071	0.079
L	0.300	0.600	0.012	0.024
θ	0°	8°	0°	8°

## SOT-23-6L Suggested Pad Layout

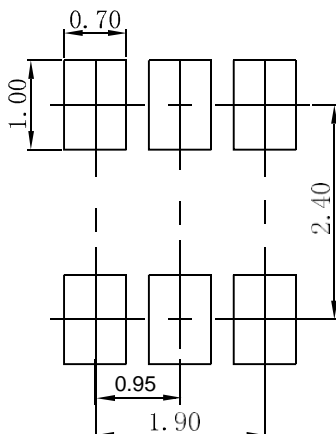

Note:

1. Controlling dimension: in millimeters.
2. General tolerance:  $\pm 0.05\text{mm}$ .
3. The pad layout is for reference purposes only.